

- Cuve ronde ou cuve rectangulaire.
- Taloches en PVC.
- Cuve avec bague et couteaux en inox.
- Sur roulettes avec freins.

- Round bowl or rectangular bowl.
- Press-segments in PVC.
- Bowl with stainless-steel ring and blades.
- On castors with locking system.

- Ronde kuip of rechthoekige kuip.
- Drukvoeten in PVC.
- Kuip met roestvrijstalen ring en messen.
- Met zwenkwielen met rem.



Diviseuse (formeuse) hydraulique
Hydraulic divider (moulder)
Hydraulische verdeler (vormer)



- 20 divisions: 100 - 950 gr.
- 20 divisions: 100 - 950 gr.
- 20 verdelingen: 100 - 950 gr.



- Poignées de position.
- Position handles.
- Verplaatshendels.

- Lames et cuve en Inox.
- Stainless steel bowl and blades.
- RVS kuip en messen

- Remontée automatique des couteaux.
- Automatic blade lifting system.
- Automatische messenlift.



- Silencieux.
- Low noise.
- Stil.

- Option chassis en Inox.
- Option stainless steel body.
- Optie RVS behuizing.

- Sur roulettes avec freins.
- On castors with locking system.
- Met zwenkwielen met rem.



- Accès facile pour le nettoyage.
- Easy access for cleaning.
- Onderhoudsvriendelijk.

- Moteur et pompe à l'abri de la poussière et de la pâte.
- Motor and pump protected from dust and dough intrusions.
- Motor en pomp beschermd tegen contact met stof en deeg.

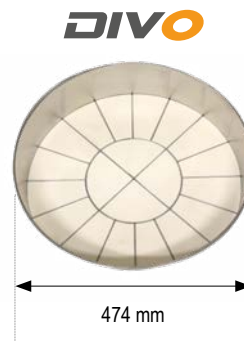

- Cadre en fonte d'aluminium avec grilles interchangeables
- Cast aluminum frame with interchangeable grids.
- Gegoten aluminium frame met verwisselbare roosters.



- Fermeture anti-projection de farine.
- Anti-flour projection closure.
- Anti-bloemprojectie sluiting.

Pour des pâtes très hydratées.

For highly hydrated dough.

Voor hoog gehydrateerd deeg.

75%

Production jusqu'à 2500 pièces/heure

Production up to 2500 pieces/hour

Productie tot 2500 stukken/uur

DIVOTRAD

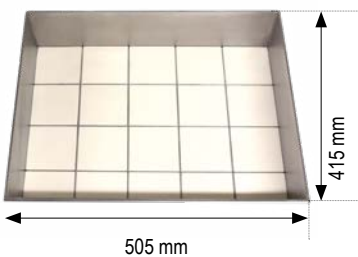

- Tapis en silicone.
- Silicon mat.
- Silicone mat.



- Plaque de tassage en matière rigide.
- Hard pressing plate.
- Harde drukplaat.

- Reglage pression.
- Pressure adjustment.
- Drukregelaar.

- Option chassis en Inox.
- Option stainless steel body.
- Optie RVS behuizing.



Option: Echelle inox | Inox trolley
 Optie: RVS rek

Bacs Bins Bakken	14
Couvercles Lids Dekfels	14
Capacité Capacity Capaciteit	9,8 L (5 - 6 kg)

Demandez notre catalogue grilles avec un large éventail de possibilités.

Ask for our catalogue of grids with a wide range of possibilities.

Vraag onze catalogus van de roosters, met tal van mogelijkheden.

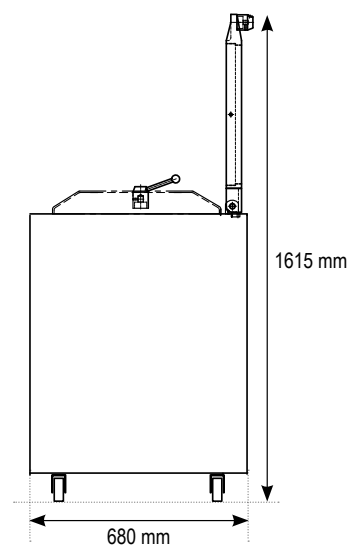
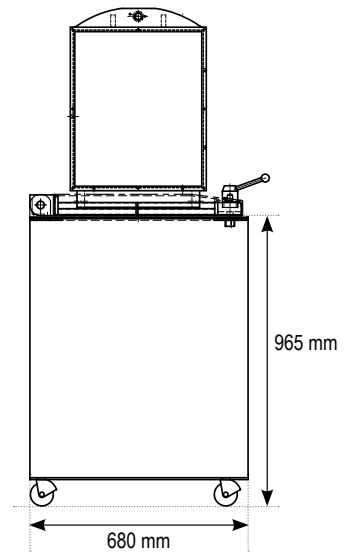

MODEL	DIVOTRAD	DIVO	DIVO
DIVISIONS DIVISIONS VERDELINGEN	20	20	20
CAPACITÉ par division CAPACITY per division CAPACITEIT per verdeling	Grid	100 - 950 g	100 - 950 g
PUISSANCE MOTEUR MOTOR POWER MOTORVERMOGEN	1,1 kW	1,1 kW	1,1 kW
POIDS NET MACHINE NET WEIGHT MACHINE NETTOGEWICHT MACHINE	285 kg	265 kg	265 kg
VOLTAGE VOLTAGE SPANNING	3Ph x 230/400V 50Hz		
OPTION ECHELLE OPTION TROLLEY OPTIE REK	✓	✓	✓
OPTION CHASSIS EN INOX OPTION BODY IN STAINLESS STEEL OPTIE BEHUIZING IN RVS	✓	✓	✓