

STOLNE FRITIZE - MANUAL TABLE FRYER -
TISCH FETTBACKGERÄT - FRIGGITRICE PER LA TAVOLA -
FREIDORA DE SOBRE MESA - НАСТОЛЬНЫЕ ФРИТЮРНИЦЫ -
FRITEUSE MANUELLE DE TABLE

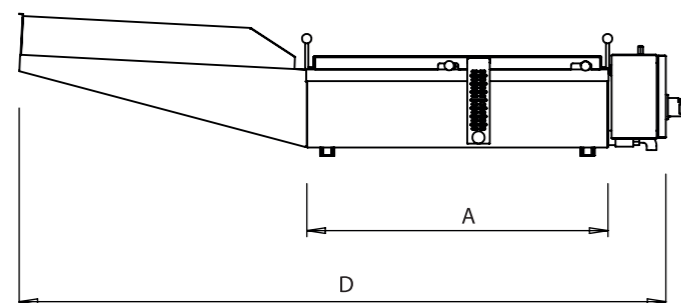

TEHNIČKI PODACI / SPECIFIKATIONS / TECHNISCHE DATEN / SPECIFICAZIONI / DATOS TÉCNICOS / ТЕХНИЧЕСКИЕ ДАННЫЕ / FICHE TECHNIQUE	FS-16	FS-24
DIMENZIJE mm / DIMENSIONS mm / GROSSE mm / DIMENSIONI mm / DIMENSIONES mm / Размеры, мм / DIMENSIONS mm	A x B x C x D 687 x 210 x 645 x 1174	A x B x C x D 880 x 210 x 645 x 1560
MASA kg / MASS kg / MASSE kg / MASSA kg / PESO kg / Bec, кг / PESANTEUR kg	50	60
SNAGA I NAPON / POWER AND VOLTAGE / LEISTUNG UND SPANNUNG / POTENZA E TENSIONE / POTENCIA ELÉCTRICA Y TENSIÓN / Мощность и подключение, кВт, В/Гц / PUISSANCE ET TENSION /	3,0 kW 230V / 50 Hz	4,5 kW 400V / 50 Hz
KAPACITET kom/h / CAPACITY pcs/h / STUNDENLEISTUNG Stück/h / CAPACITA pc/h / CAPACIDAD unidades/hora / Производительность, шт/ч / CAPACITÉ pièces/heure	160	240

RUČNE FRITIZE - MANUAL FRYER WITH CHAMBER -
MANUAL FETTBACKGERÄTE - FRIGGITRICE A MANO -
FREIDORAS MANUALES - РУЧНЫЕ ФРИТЮРНИЦЫ -
FRITEUSE MANUELLE AVEC CHAMBRE

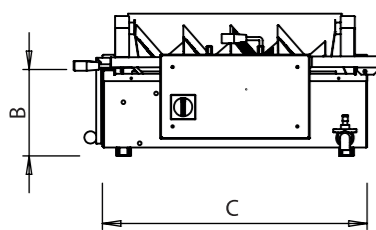
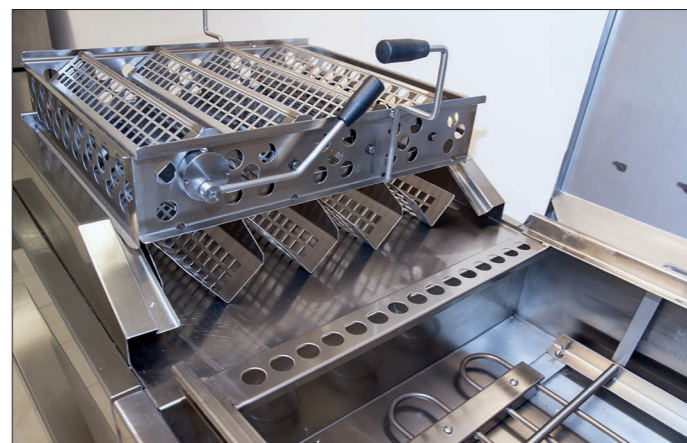
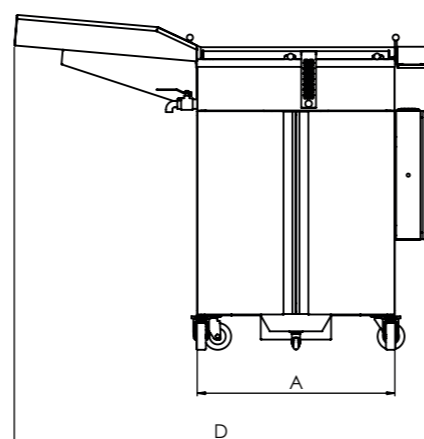
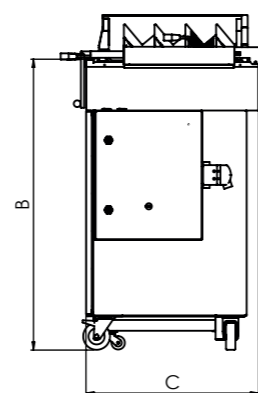

TEHNIČKI PODACI / SPECIFIKATIONS / TECHNISCHE DATEN / SPECIFICAZIONI / DATOS TÉCNICOS / ТЕХНИЧЕСКИЕ ДАННЫЕ / FICHE TECHNIQUE	FR-16 K (FR-16 BK)	FR-24 K (FR-24 BK)
DIMENZIJE mm / DIMENSIONS mm / GROSSE mm / DIMENSIONI mm / DIMENSIONES mm / Размеры, мм / DIMENSIONS mm	A x B x C x D 667 x 1080 x 645 x 1154	A x B x C x D 880 x 1080 x 645 x 1540
MASA kg / MASS kg / MASSE kg / MASSA kg / PESO kg / Bec, кг / PESANTEUR kg	100	110
SNAGA I NAPON / POWER AND VOLTAGE / LEISTUNG UND SPANNUNG / POTENZA E TENSIONE / POTENCIA ELÉCTRICA Y TENSIÓN / Мощность и подключение, кВт, В/Гц / PUISSANCE ET TENSION /	3,8 kw (3,0 kW) 230V / 50 Hz	5,3 kw (4,5 kW) 400V / 50 Hz
KAPACITET kom/h / CAPACITY pcs/h / STUNDENLEISTUNG Stück/h / CAPACITA pc/h / CAPACIDAD unidades/hora / Производительность, шт/ч / CAPACITÉ pièces/heure	160	240



Europska unija
Zajedno do fondova EU

Projekt je sufinancirala Europska Unija iz Europskog fonda za regionalni razvoj / Sadržaj publikacije isključiva je odgovornost IZO d.o.o.



CROATIA - 52207 BARBAN - Barban 164, B. Z. Barban
Headquarter: 52341 ŽMINJ - Balići 18
Production: 52207 BARBAN - Barban 164, B. Z. Barban
Tel.: ++385(0)52 355 013, ++385(0)52 355 016 ♦ Fax: ++385(0)52 300 280
E-mail: prodaja@izo.hr ▪ www.izo.hr

- Friteze za krafne
- Doughnut fryers
- Fettbackgerate
- Friggitrici per ciambele/krapfen
- Freidoras de Donut y Bollería
- Фритюрницы для пончиков
- Friteuses de beignets



- *Inox izvedba - Stainless steel - Edeltahlkonstruktion - Design in acciaio inox - Construidas en acero inoxidable de elevada robustez - Конструкция из нержавеющей стали - acier inoxydable*
- *one - De fácil limpieza y mantenimiento sencillo - Легкая чистка - facile à nettoyer et à entretenir*
- *Kvalitetno pečenje - Quality baking - Ausgezeichnete Backqualität - Cottura di qualità - Cocción de calidad uniforme - Высокое качество жарки - cuisson de qualité*
- *Jednostavno posluživanje - Easy service - Einfache Handhabung - Facile per usare - Utilización sencilla e intuitiva - Простота обслуживания - facile à utiliser*
- *Jednostavno čišćenje i održavanje - Easy to clean and service - Einfache Reinigung und Instandhaltung - Faccile per pulire e manutenzi-*

POLUAUTOMATSKE FRITZEZE S KOMOROM • SEMI-AUTOMATIC FRYER WITH THE CHAMBER • HALBAUTOMATISCHE FETTBACKGERÄTE MIT GÄRSCHRANK • FRIGGITRICE SEMIAUTOMATICA CON CELLA • FREIDORA SEMI-AUTOMÁTICA CON CÁMARA DE FERMENTACIÓN • ПОЛУАВТОМАТИЧЕСКИЕ ФРИТЮРНИЦЫ С РАССТОЙКОЙ • FRITEUSE SEMI-AUTOMATIQUE SANS CHAMBRE

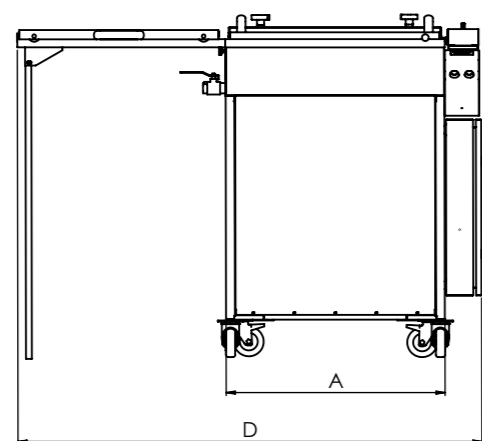
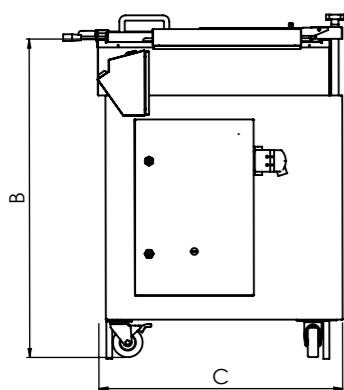

TEHNIČKI PODACI / SPECIFIKATIONS / TECHNISCHE DATEN / SPECIFICAZIONI / DATOS TÉCNICOS / ТЕХНИЧЕСКИЕ ДАННЫЕ / FICHE TECHNIQUE	FP-36 K	FP-48 K	FP-60 K
DIMENZIJE mm / DIMENSIONS mm / GROSSE mm / DIMENSIONI mm / DIMENSIONES mm / Размеры, мм / DIMENSIONS mm	A x B x C x D 860 x 1075 x 820 x 1560	A x B x C x D 1050 x 1075 x 820 x 1942	A x B x C x D 1243 x 1075 x 820 x 2315
MASA kg / MASS kg / MASSE kg / MASSA kg / PESO kg / Вес, кг / PESANTEUR kg	130	175	220
SNAGA I NAPON / POWER AND VOLTAGE / LEISTUNG UND SPANNUNG / POTENZA E TENSIONE / POTENCIA ELÉCTRICA Y TENSIÓN / Мощность и подключение, кВт, В/Гц / PUISSANCE ET TENSION /	8,2 kW 400V / 50 Hz	8,6 kW 400V / 50 Hz	10,4 kW 400V / 50 Hz
KAPACITET kom/h / CAPACITY pcs/h / STUNDENLEISTUNG Stück/h / CAPACITA pc/h / CAPACIDAD unidades/hora / Производительность, шт/ч / CAPACITÉ pièces/heure	360	480	600

POLUAUTOMATSKE FRITZEZE BEZ KOMORE • SEMI-AUTOMATIC FRYER WITHOUT CHAMBER • HALBAUTOMATISCHE FETTBACKGERÄTE OHNE GÄRSCHRANK • FRIGGITRICE SEMIAUTOMATICA SENZA CELLA • FREIDORA SEMI-AUTOMÁTICA SIN CÁMARA DE FERMENTACIÓN • ПОЛУАВТОМАТИЧЕСКИЕ ФРИТЮРНИЦЫ БЕЗ РАССТОЙКИ • AUTOMATIQUE FRITEUSE SANS CHAMBRE



TEHNIČKI PODACI / SPECIFIKATIONS / TECHNISCHE DATEN / SPECIFICAZIONI / DATOS TÉCNICOS / ТЕХНИЧЕСКИЕ ДАННЫЕ / FICHE TECHNIQUE	FP-36 BK	FP-48 BK	FP-60 BK
DIMENZIJE mm / DIMENSIONS mm / GROSSE mm / DIMENSIONI mm / DIMENSIONES mm / Размеры, мм / DIMENSIONS mm	A x B x C x D 860 x 1075 x 820 x 1560	A x B x C x D 1050 x 1075 x 820 x 1942	A x B x C x D 1243 x 1075 x 820 x 2315
MASA kg / MASS kg / MASSE kg / MASSA kg / PESO kg / Вес, кг / PESANTEUR kg	105	150	195
SNAGA I NAPON / POWER AND VOLTAGE / LEISTUNG UND SPANNUNG / POTENZA E TENSIONE / POTENCIA ELÉCTRICA Y TENSIÓN / Мощность и подключение, кВт, В/Гц / PUISSANCE ET TENSION /	7,4 kW 400V / 50 Hz	7,4 kW 400V / 50 Hz	9,2 kW 400V / 50 Hz
KAPACITET kom/h / CAPACITY pcs/h / STUNDENLEISTUNG Stück/h / CAPACITA pc/h / CAPACIDAD unidades/hora / Производительность, шт/ч / CAPACITÉ pièces/heure	360	480	600

AUTOMATSKE FRITZEZE S I BEZ KOMORE • AUTOMATIC FRYER WITH AND WITHOUT CHAMBER • AUTOMATISCHE FETTBACKGERÄTE MIT UND OHNE GÄRSCHRANK • FRIGGITRICE AUTOMATICA CON E SENZA CELLA • FREIDORA SEMI-AUTOMÁTICA CON Y SIN CÁMARA DE FERMENTACIÓN • АВТОМАТИЧЕСКИЕ ФРИТЮРНИЦЫ С РАССТОЙКОЙ И БЕЗ • AUTOMATIQUE FRITEUSE AVEC ET SANS CHAMBRE

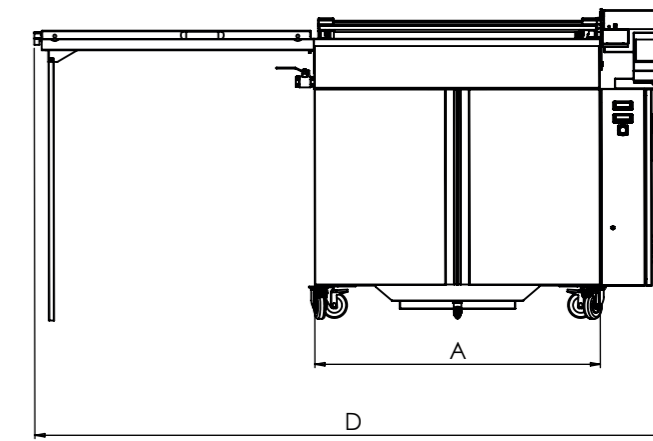
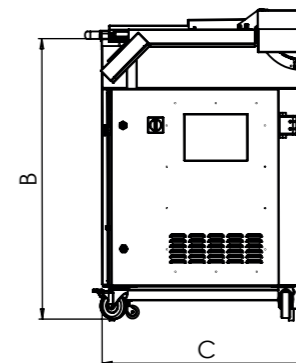

TEHNIČKI PODACI / SPECIFIKATIONS / TECHNISCHE DATEN / SPECIFICAZIONI / DATOS TÉCNICOS / ТЕХНИЧЕСКИЕ ДАННЫЕ / FICHE TECHNIQUE	FA-60 K	FA-60 BK
DIMENZIJE mm / DIMENSIONS mm / GROSSE mm / DIMENSIONI mm / DIMENSIONES mm / Размеры, мм / DIMENSIONS mm	A x B x C x D 1400 x 1075 x 820 x 2500	A x B x C x D 1400 x 1075 x 820 x 2500
MASA kg / MASS kg / MASSE kg / MASSA kg / PESO kg / Вес, кг / PESANTEUR kg	220	195
SNAGA I NAPON / POWER AND VOLTAGE / LEISTUNG UND SPANNUNG / POTENZA E TENSIONE / POTENCIA ELÉCTRICA Y TENSIÓN / Мощность и подключение, кВт, В/Гц / PUISSANCE ET TENSION /	10,4 kW 400V / 50 Hz	9,2 kW 400V / 50 Hz
KAPACITET kom/h / CAPACITY pcs/h / STUNDENLEISTUNG Stück/h / CAPACITA pc/h / CAPACIDAD unidades/hora / Производительность, шт/ч / CAPACITÉ pièces/heure	600	600