

**EIGENSCHAFTEN**

- Robuste Maschine.
- PVC Transportbänder.
- Manuelle Bedienung:  
**SM-520S:** mit Drucktasten.  
**SM-520F:** mit Hebel.
- Geschwindigkeit 50 cm/s.
- Aufklappbare Tische.

**CARACTERÍSTICAS**

- Máquina robusta.
- Cintas transportadoras de PVC.
- Manejo:  
**SM-520S:** con botónes.  
**SM-520F:** con palanca.
- Velocidad: 50 cm/s.
- Mesas abatibles.

**CARATTERISTICHE**

- Macchina robusta.
- Nastri trasportatori in PVC.
- Azionamento manuale:  
**SM-520S:** a pulsanti.  
**SM-520F:** a leva.
- Velocità 50 cm/sec.
- Piani pieghevoli verso l'alto.



Aufklappbare Tische.  
Mesas abatibles.  
Piani pieghevoli verso l'alto.

PVC Transportbänder.  
Cintas transportadoras de PVC.  
Nastri trasportatori in PVC.



Ausgestattet mit Schwenkrädern mit Bremse, leicht zu bewegen.

Dotada de ruedas giratorias con freno, fácil de desplazar.

Montata su ruote bloccabili, facile da muovere

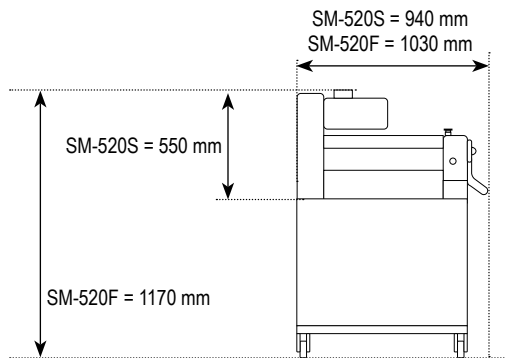
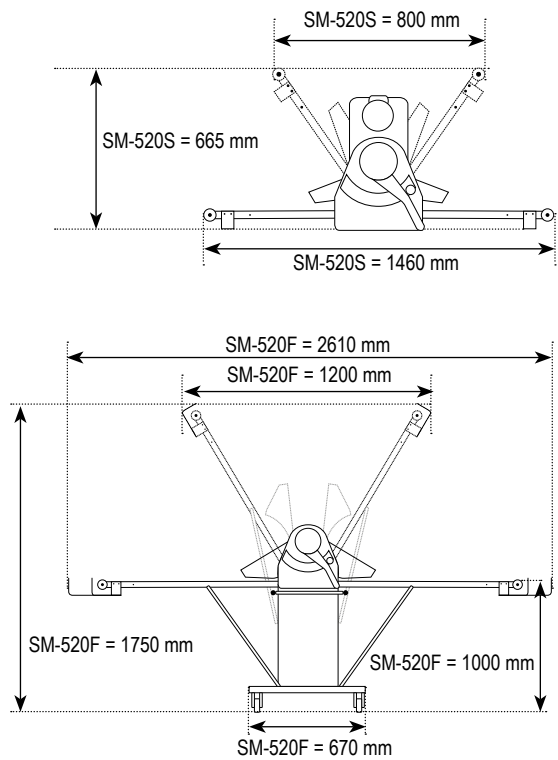
**SEITENANSICHT | PERFIL | VISTA LATERALE**

**VORDERANSICHT | ALZADO | VISTA FRONTALE**

**SM-520S**

**SM-520F**

MODEL	SM-520S	SM-520F
MODELL MIT SOCKEL   MODELO CON BASE   MODELLO CON SUPPORTO	✗	✓
MOTORLEISTUNG   POTENCIA MOTOR   POTENZA MOTRICE	0,37 kW	0,55 kW
NETTOGEWICHT MASCHINE   PESO NETO MÁQUINA   PESO NETTO MACCHINA	100 kg	168 kg
AUSROLLBREITE   ANCHO DE LAMINADO   LARGHEZZA DI LAMINAZIONE	520 mm	520 mm
LÄNGE TRANSPORTBAND   LONGITUD CINTAS   LUNGHEZZA DEL NASTRO	2 x 670 mm	2 x 980 mm
ABSTAND ZWISCHEN DEN ROLLEN   DISTANCIA ENTRE RODILLOS   SPAZIO TRA I RULLI	1 - 30 mm	1 - 30 mm
SPANNUNG   VOLTAJE   VOLTAGGIO	230/400V 3Ph 50Hz 230V 1Ph 50Hz	x 230/400V 50Hz